

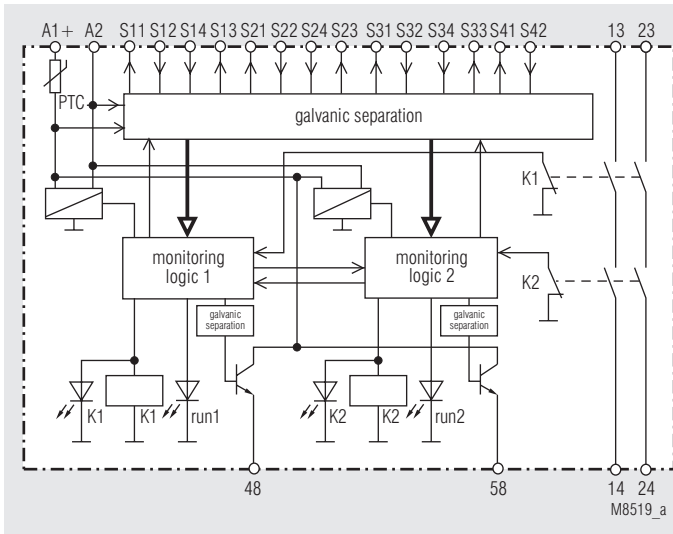

Block Diagram



Indication

- green LED's K1, K2: On, when relays K1 and K2 are energized.
- yellow LED run 1: On continuously, when no fault and the valve is in initial position.
Off, when no fault and the valve is in end position.
Indicates faults by different flashing sequences (see flashing codes for fault indication).
- yellow run 2: On continuously, when no fault.
Indicates internal faults by different flashing sequences (see flashing codes for fault indication).

Output
48 and 58:

48	58	
+24Volt	+24Volt	No fault or feed back circuit open
0 Volt	0 Volt	Other fault then valve failure or feed back circuit open
+24Volt	0 Volt	Starting failure of valve
0 Volt	+24Volt	Reset failure of valve

- According to
 - Performance Level (PL) e and category 4 to EN ISO 13849-1: 2008
 - SIL Claimed Level (SIL CL) 3 to IEC/EN 62061
 - Safety Integrity Level (SIL 3) to IEC/EN 61508
 - Category 4 to EN 954-1
- Way of valve monitoring adjustable (2 NC, 2NO, 1 changeover contact)
- Reset button to acknowledge after fault detection
- Available with continuous monitoring of the valve or just with one check per cycle
- Contact reinforcement by external contactors possible
- Short circuit and cross fault detection
- Broken wire detection
- Outputs: 2 NO contacts
- 2 semiconductor outputs with short circuit, overload and temperature protection to monitor the status
- Under and overvoltage detection
- Reaction time: max. 28 ms
- LED operation indicators (run 1, run 2)
- Width 45 mm

Approvals and Marking



* see variants

Application

- Protection of people and machines.
The module BH 5904 monitors the positions of valve lifter in standard hydraulic blocks for presses.

Function

The module BH 5904 monitors the position of the valve at the beginning of a machine cycle by checking a position sensor. The output contacts are only activated if on start signal from the safety controller the valve is in its initial position, the feed back circuit from the safety controller is closed and no fault is stored.

The output contacts are deactivated or cannot be activated again, when after an adjustable time delay the valve position does not correspond to the start signal.

Two types of machine cycles can be selected:

- The cycle ends when feed back circuit of the safety controller is interrupted. The valve will only be monitored when switching the start signal for the first time.
- The cycle ends when switching off the start signal by the safety controller. In this case the valve will be monitored continuously.

Because of the potential free inputs it is possible to connect as many modules BH 5904 as required, which monitor different valves to the same feed back circuit.

Notes

- Adjustments on the unit may only be carried out by qualified specialist staff when the unit is disconnected from the supply.
- Before removing the front plate of the unit potential equalisation must be made.
- The module is a passive monitoring device which does not start any dangerous movement. It prevents against dangerous movement together with the safety controller it when it detects a failure in its monitoring area. The safety controller therefore has to have a feed back circuit.

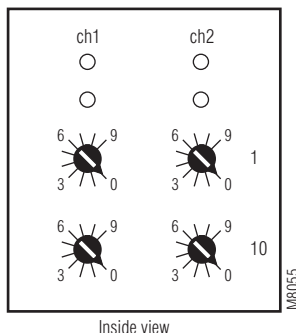
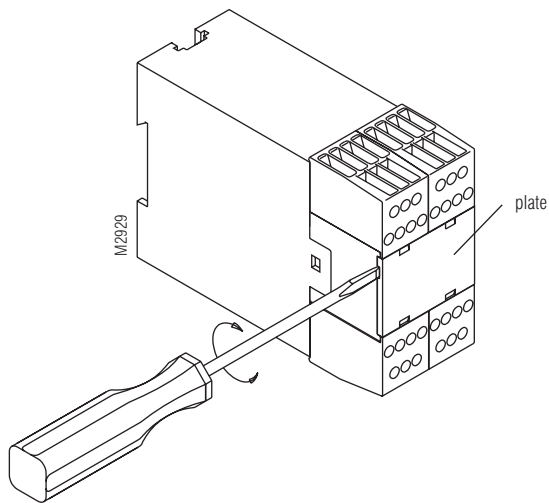

The setting of the function of the BH 5904 is done with 4 rotational switches located behind the front plate shown in the picture. The switches on the left select the function on processor 1 and the switches on the right of processor 2. For both processors the setting must be the same.

Example for setup:

Function to be selected: status sensor on valve is C/O contact, 1 valve test per machine cycle, max. 1 s.
 Set both upper switches to 5
 Set both lower switches to 1

	Time in which the valve has to react									
SW 1	0	1	2	3	4	5	6	7	8	9
(s)	0,5	0,61	0,72	0,83	0,94	1,05	1,16	1,27	1,38	1,49

SW. 10 :	Selection of operating mode		
	Valve status sensor	Valve monitoring mode	Contact reinforcement
0	S21-S22 : NC, S23-S24: NC	1 test per machine cyclic	Without contact reinforcement
1	S21-S22 : NO, S23-S24: NC		
2	S21-S22 : NO, S23-S24: NO	Continuous monitoring of the valve	
3	S21-S22 : NC, S23-S24: NC		
4	S21-S22 : NO, S23-S24: NC		
5	S21-S22 : NO, S23-S24: NO		
6	S21-S22 : NC, S23-S24: NC		
7	S21-S22 : NO, S23-S24: NC		
8	S21-S22 : NO, S23-S24: NO	With contact reinforcement	
9	not allowed		

Operating Modes

At the beginning of a machine cycle the following conditions for the initial state of the module have to be fulfilled, before the start signal of the safety controller can activate the relays K1 and K2:

- The feed back circuit of the safety controller must be closed.
- The starting signal must be inactive.
- At the end of the previous cycle the valve has to have returned to it's initial position within the required time.
- The module must not show any stored fault.

The relays K1 and K2 are activated with the positive edge of the starting signal of the controller.

The relays de-energise and the module locks out if the valve has not reached it's end position in the required maximum time or if the starting signal is switched off before the valve has reached its end position. The momentary state of the valve is indicated by the LED run 1.

A started cycle is finished in all operating modes by interrupting the feed back circuit.

Reset button

A reset button can be connected to terminals S33-S34 to reset the module without disconnecting the supply voltage.

The reset requires pressing and releasing of the push button and all other signals to be in initial state. Reset is only made if the push button is not longer activated then 3 seconds.

Contact reinforcement

If more contacts are needed or higher currents have to be switched then the unit can handle on K1, K2, the feed back contacts of external contactors can be connected to terminals S41-S42 (2 NC contacts, see pic. 2), which signal the status of these contactors to the BH 5904. The BH 5904 monitors continuously if this input corresponds to the state fo K1 and K2. On failure (more then 100 ms after switching K1 and K2 no equivalent status) K1 and K2 disconnect or do not energise at all. The module BH 5904 can only be reset after removing of the failure by pressing the reset button. Contact reinforcement is only available with functions having continuous valve monitoring (switch 10 = 6, 7 and 8).
 If contact reinforcement is not used, terminals S41-S42 remain open.

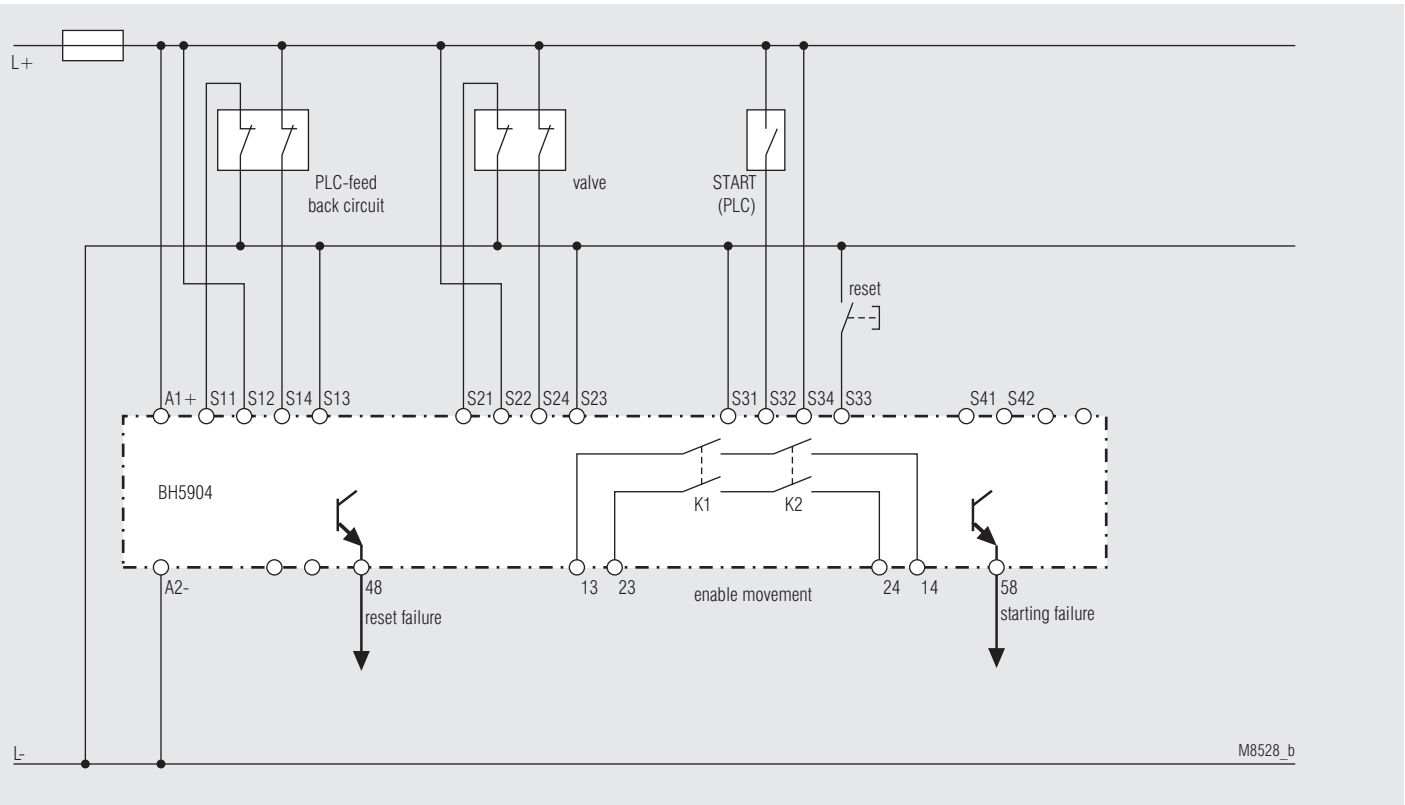

Pic.: 1
 Connection without contact reinforcement of contacts, valve sensor 2 NC contacts (same connection as for 2 NO contacts)
 (switch 10: position 0, 2, 3 or 5)

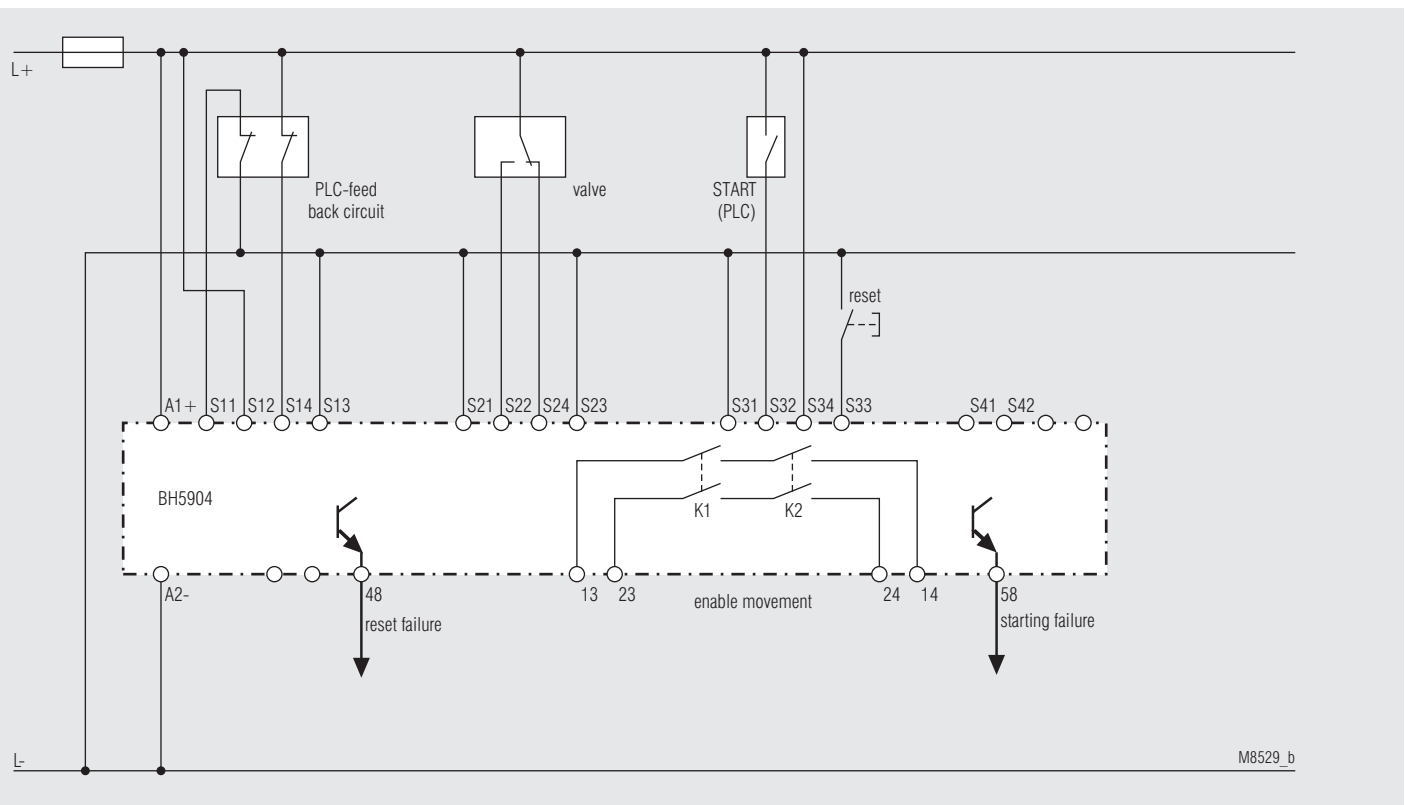

Pic.: 2
 Connection without contact reinforcement of contacts, valve sensor 1 changeover contact (switch 10: position 1, 4 or 7)

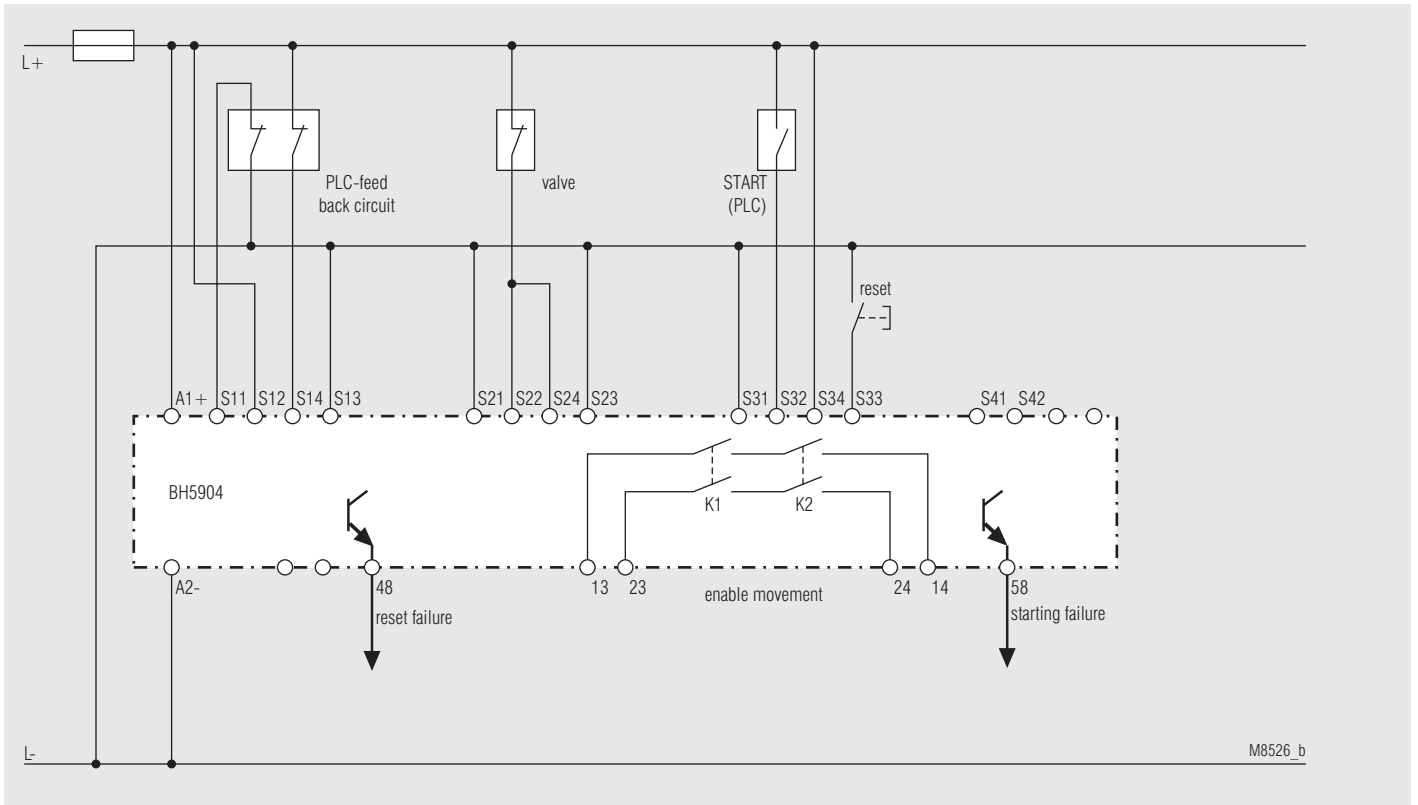

Pic.: 3
 Connection without contact reinforcement of contacts, valve sensor 1 NC contact (same connection as for 1 NO contact)
 (switch 10: position 0, 2, 3 or 5)

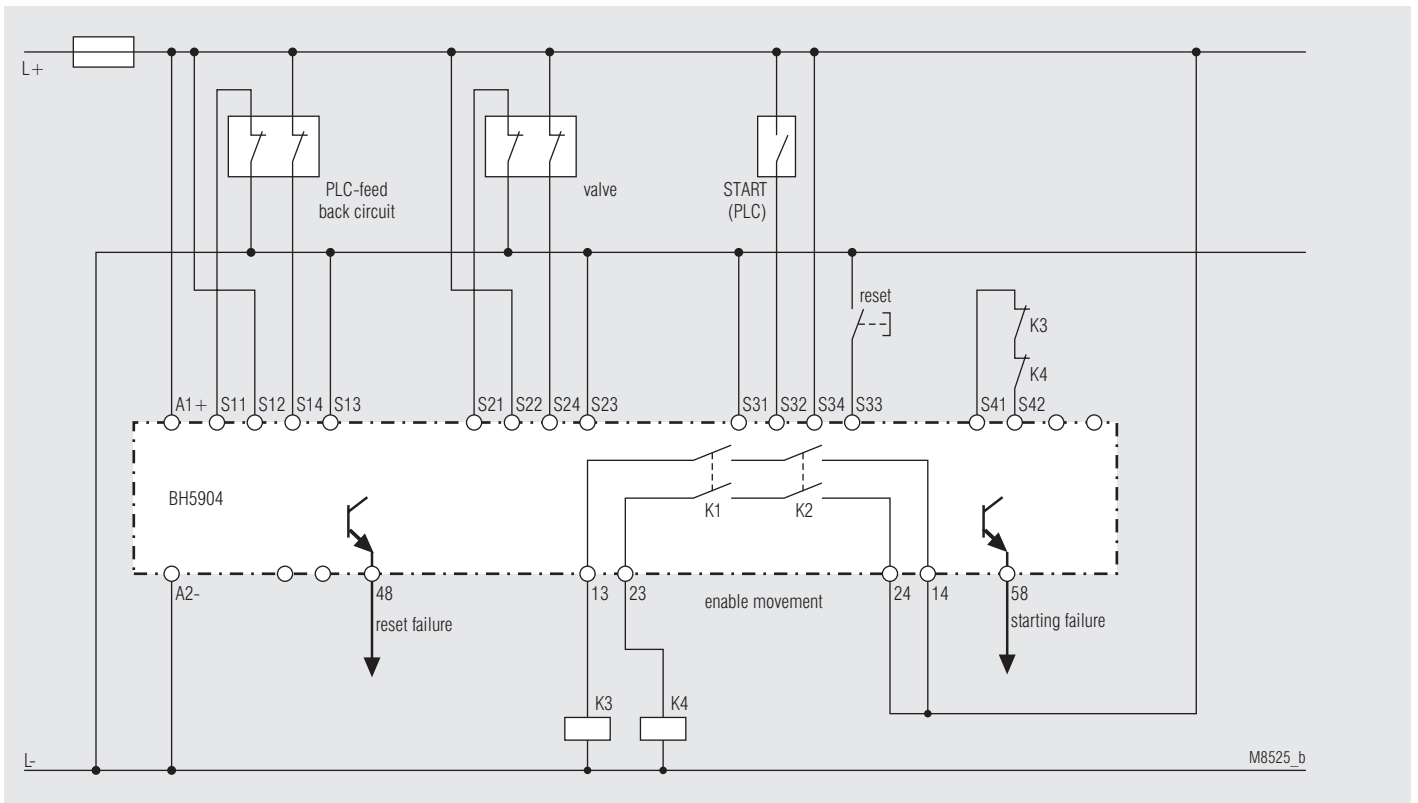

Pic.: 4
 Connection with contact reinforcement of contacts (switch 10: position 6)
 (when using 2 NO contacts (switch 10: position 8) or 1 changeover contact (switch 10: position 7) the connection of contact reinforcement is identically)

Application Example

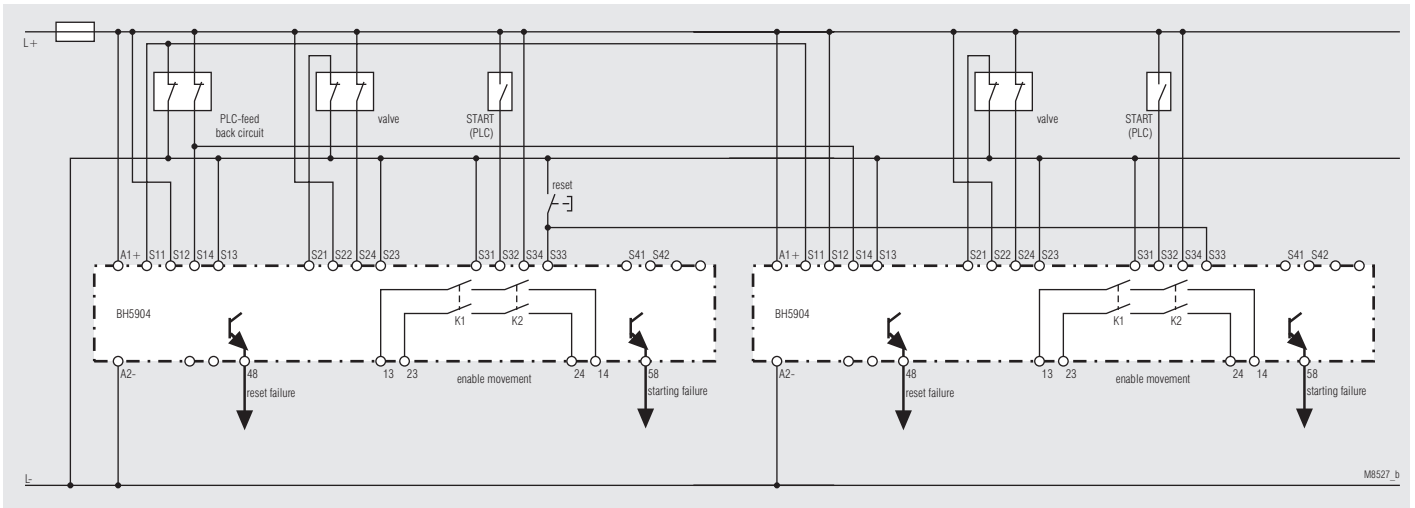

Pic.: 5
Connection when several modules are connected to one feed back circuit and one reset button.

Operating Modes

The valves are continuously monitored, and failures are only during test cycles indicated by the semiconductor outputs 48 (release failure) and 58 (starting failure). In the following cases the relays K1 and K2 are de-energized or do not energise at all:

- If all signals except feed back circuit are not in initial state when auxiliary supply is connected.
- If at the beginning of a machine cycle after the first activation by the starting signal the valve does not reach the end state within adjusted time. With the first activation the starting signal has to stay so long that the end position can be indicated.
- If at the beginning of a machine cycle after the first activation by the starting signal the valve does reach the end position and leaves this position before the starting signal gets inactive.

- If at the end of a machine cycle (interruption of feed back circuit or, when continuous monitoring, negative edge of the starting signal) the valve does not go back into initial position.
- If the signal on S41-S42 does not correspond after max. 100 ms to the state of the relays, when reinforcement of the contacts is selected.

Function Diagram (valve status sensed by NC contacts)

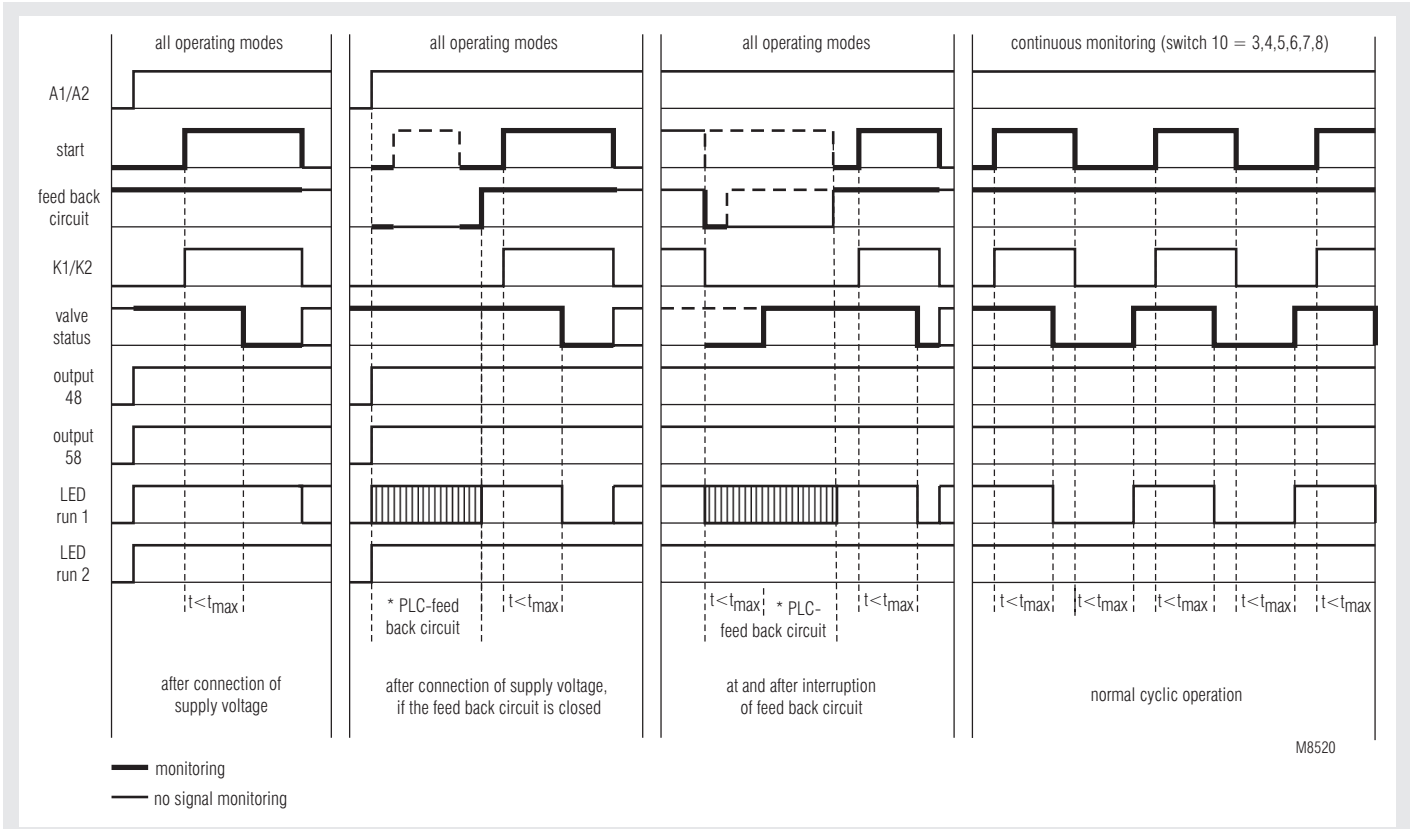

Phases of valve monitoring

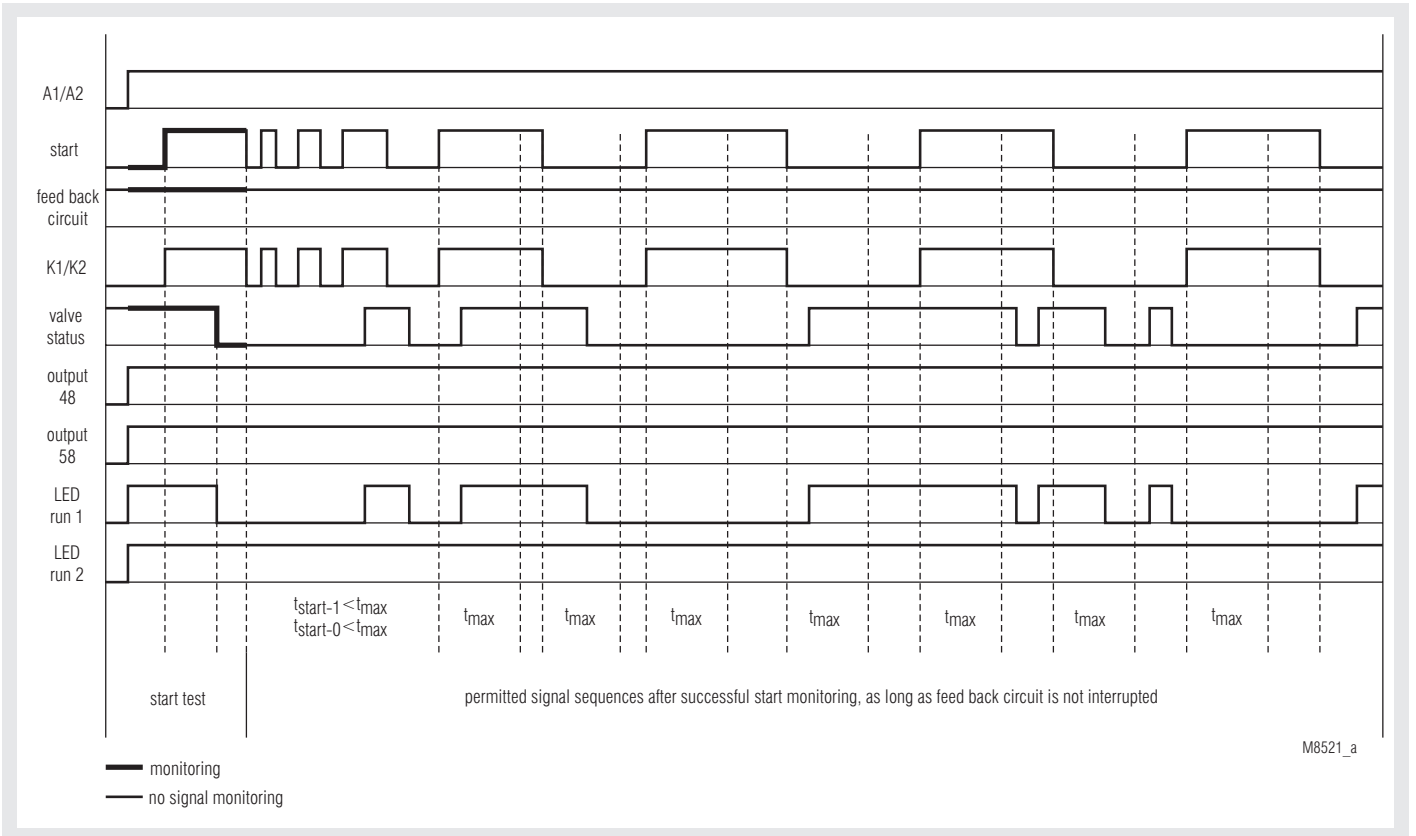

Operating modes without continuous valve monitoring (switch 10 = 0, 1 or 2)

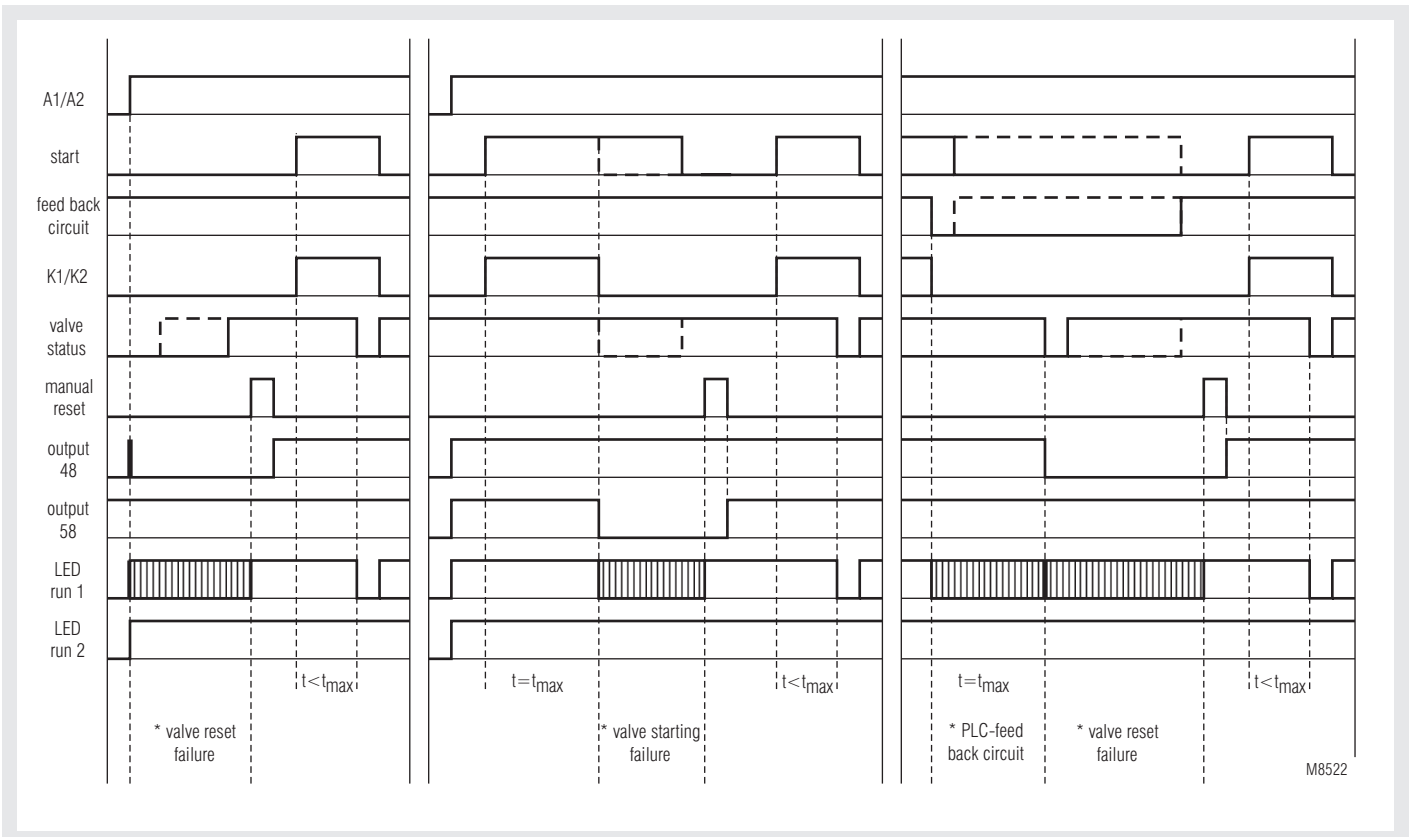

Behaviour when failure detected

Circuit Diagram

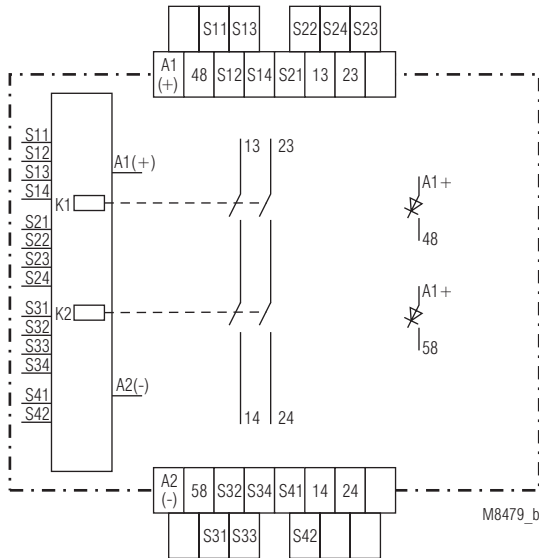

BH 5904.02

Characteristic

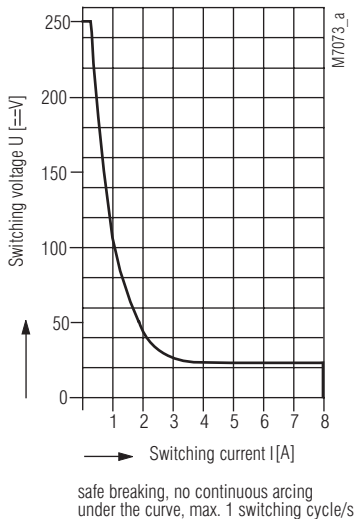

Arc limit curve

Technical Data

Input

Nominal voltage U_N:	DC 24 V
Voltage range:	
at max. 5 % residual ripple:	0.85 ... 1.15 U_N
Nominal consumption:	max. 170 mA (semiconductor outputs without load)
Control voltage via S41, 48, 58:	DC 23 V at U_N
Control current via S11-S12, S13-S14, S21-S22, S23-S24, S31-S32, S33-S34, S41-S42:	each 4.5 mA at U_N
Minimum voltage for active signal between terminals S11-S12, S13-S14, S21-S22, S23-S24, S31-S32, S33-S34 und S42:	DC 16 V
Maximum voltage for inactive signal between terminals S11-S12, S13-S14, S21-S22, S23-S24, S31-S32, S33-S34 und S42:	DC 7V
Fusing:	Internal with PTC
Max. discrepancy of the signals of the feed back circuit S12-S14 against S22-24:	100 ms

Output

Contacts	
BH 5904.02:	2 NO contacts
Type of contact:	Relay, forcibly guided
Reaction times at U_N	
Start of controller when start signal applied:	max. 41 ms
Drop out time at interruption of start signal:	max. 28 ms
Drop out time at interruption of feed back circuit:	max. 28 ms at U_N
Nominal output voltage:	AC 250 V DC: see arc limit curve
Switching of low loads:	≥ 100 mV
Thermal current I_{th}:	5 A
Switching capacity to AC 15	
NO contact:	3 A / AC 230 V IEC/EN 60 947-5-1
NC contact:	2 A / AC 230 V IEC/EN 60 947-5-1
to DC 13 at 0.1 Hz:	8 A / DC 24 V IEC/EN 60 947-5-1
Electrical life to AC 15 at 2 A, AC 230 V:	10^5 switching cycles IEC/EN 60 947-5-1
Permissible operating frequency:	max. 1 200 switching cycles / h
Short circuit strength	
max. fuse rating:	6 A gL IEC/EN 60 947-5-1
line circuit breaker:	C 8 A
Mechanical life:	10×10^6 switching cycles

Semiconductor Outputs

Output (terminal 48 and 58):	Transistor outputs, plus-switching
Output voltage:	DC 24 V, max. 100 mA continuous current, max. 400 mA for 0.5 s internal short circuit, overtemperature and overload protection.

General Data

Operating mode:	Continuous operation
Temperature range	
operation:	± 0 ... + 50 °C
storage :	- 25 ... + 85 °C
altitude:	< 2.000 m
Clearance and creepage distances	
rated impuls voltage / pollution degree:	4 kV / 2 (basis insulation) IEC 60 664-1

Technical Data

EMC		
Electrostatic discharge:	8 kV (contact) (Test degree 3)	IEC/EN 61 000-4-2
HF-irradiation:	10 V / m	IEC/EN 61 000-4-3
Fast transients:		
on wires for supply A1-A2:	2 kV	IEC/EN 61 000-4-4
on signal and control wires:	2 kV	IEC/EN 61 000-4-4
Surge voltages		
between wires for supply:	1 kV	IEC/EN 61 000-4-5
between wire and ground:	2 kV	IEC/EN 61 000-4-5
HF-wire guided:	10 V	IEC/EN 61 000-4-6
Interference suppression:	Limit value class B	EN 55 011
Degree of protection		
Housing:	IP 40	IEC/EN 60 529
Terminals:	IP 20	IEC/EN 60 529
Housing: Thermoplastic with V0-behaviour to UL subject 94		
Vibration resistance: according to IEC/EN 61 496-1 (1997) Amplitude 0.35 mm IEC/EN 60 068-2-6 Frequency 10 ... 55 Hz		
Shock resistance:		
Acceleration:	10 g	
Impulse length:	16 ms	
Number of shocks:	1000 per axis on all three axes	
Climate resistance: 0 / 050 / 04 IEC/EN 60 068-1		
Terminal designation: EN 50 005		
Wire connection: 1 x 2.5 mm ² stranded wire with sleeve or 1 x 4 mm ² massive or 2 x 1.5 mm ² stranded wire with sleeve DIN 46 228-1/-2/-3/-4		
Wire fixing: Box terminals with self lifting wire Protection and plus-minus screws M3.5		
Mounting: DIN rail IEC/EN 60 715		
Weight: 320 g		

Dimensions

Width x height x depth: 45 x 84 x 121 mm

Safety Related Data

Values according to EN ISO 13849-1:

Kategorie:	4	
PL:	e	
MTTF _d ¹⁾ :	31.9	a
DC / DC _{avg} ¹⁾ :	98.9	%
d _{op} :	220	d/a (days/year)
h _{op} :	12	h/d (hours/day)
t _{Zyklus} :	97	s/Zyklus

Values according to IEC/EN 62061 / IEC/EN 61508:

SIL CL:	3	IEC/EN 62061
SIL:	3	IEC/EN 61508
HFT:	1	
DC / DC _{avg} ¹⁾ :	98.9	%
SFF:	99.6	%
PFH _D :	7.66E-9	h ⁻¹

¹⁾ HFT = Hardware-Failure-Tolerance



The values stated above are valid for the standard type.

Safety data for other variants are available on request.

The safety relevant data of the complete system has to be determined by the manufacturer of the system.

UL-Data

The safety functions were not evaluated by UL. Listing is accomplished according to requirements of Standard UL 508, "general use applications"

Nominal voltage U_N: DC 24 V

Ambient temperature: 0 ... +50°C

Switching capacity:
Ambient temperature 50°C: Pilot duty B300
5A 250Vac G.P.
5A 24Vdc
Semiconductor outputs: 24Vdc, 100 mA

Wire connection: 60°C / 75°C copper conductors only
AWG 20 - 12 Sol Torque 0.8 Nm
AWG 20 - 14 Str Torque 0.8 Nm



Technical data that is not stated in the UL-Data, can be found in the technical data section.

Standard Type

BH 5904.02/00MF2 DC 24 V

Article number: 0055225
• Output: 2 NO contacts
• All functions settable via rotational switches
• Nominal voltage U_N: DC 24 V
• Width: 45 mm

Ordering example

BH 5904 .02 /00MF2 DC 24 V
Nominal voltage
Contacts
Type

Variant

BH 5904.02/00MF2/61: With UL approval

Fault Indication by flashing code

The failure codes are displayed by a flashing sequence of the upper yellow LEDs run 1, run 2. Flashing frequency: env. 0,5 s on, 0,05 s off, end of the sequence: env. 2 s off. It is possible that the two processors show different failure codes.

If a failure is displayed, the relays K1 and K2 are switched off.

The module BH 5904 shows 2 types of failure codes:

1. FAILURE type 1:

These failures are serious and do not allow further operation of the module. They are indicated only by the LEDs run 1 and / or run 2 of the module. The semiconductor outputs 48 and 58 are both switched off. The module can only be reset by switching the power supply off and on again.

2. FAILURE type 2:

This failure is concerning the function faults in conjunction with the safety controller and / or the monitored valve. These faults are only indicated on LED run 1, the LED run 2 stays on. The module locks out except in the case when the feed back circuit of the controller is interrupted. It can only be reset by switching the power supply off and on again or by pressing the reset button.

Failure type 1

N ^o *)	Description	Mesures et conseils
0	Internal module failure (LEDs are continuously off)	If both LEDs stay off, the module is defective and has to be repaired.
5	Adjustment failure	1) The settings of the 2 channels are not identical. 2) The selected setting is not permitted.
6	Undervoltage detection or Overvoltage detection	1) Left LED is flashing: The supply voltage dropped below the permitted value (< approx. 0.85 U _N) 2) Right LED is flashing: The supply voltage went over the permitted value (> approx. 1.15 U _N + 5 % residual ripple)
7	Input failure	1) A short circuit has been detected on the inputs of the unit. 2) The 2 signals of a 2-channel feedback circuit do not correspond (shortcircuit, broken wire or other fault)
8	Failure on relays K1 or K2	Check circuit and current. Module has to be repaired.
9	Internal module failure	Please try to evaluate the circumstances that lead to this fault and check with the supplier or manufacturer.
10		
11		
12	Internal module failure	The module has to be repaired
13		
14		

*) No.: Number of flash pulses in a series

Failure type 2

No.*)	Description	Measures and notes
1	Valve starting failure (no end position)	The valve has not reached its end position within the adjusted time. The unit has locked out.
2	Setting failure	The valve is not in initial position when starting or has not reached the initial position after de-activation within the adjusted time. The unit has locked out.
3	Feed back circuit interrupted from safety controller	The unit is again ready for start as the feed back circuit is closed, the valve has returned back to initial position within the adjusted time and the starting signal is off.
4	Contact reinforcement failure	The reaction time for the external relays was too long. The unit has locked out.
5	PLC-starting failure	Start is active, while it should be inactive.
6	Failure on reset button	Reset button was activated while switching on or has been pressed for more than 3 s. The unit has locked out. It can be reset by releasing and pressing again the reset button or by switching the supply off and on again.

*) No.: Number of flash pulses in a series

